



# 0.26mm Motion *et*MEMS™ Free Space Attenuator Chip

(Protected by US patents pending)

## Product Description

The *et*MEMS™ series of free space variable optic attenuator (FS-VOA) is based on a proprietary patent pending micro-electro-mechanical mechanism featuring exceptionally compact size with large shutter movement, simple construction, and direct drive. The *et*MEMS™ series of FS-VOA is designed to completely block a collimated light beam  $\leq 260 \mu\text{m}$  in diameter and be operated in air without the need for hermetic seal and is fully compliant with the Telcordia 1209 and 1221 reliability standards. The device is ideally suited to be integrated into laser and coherent detection systems.

The different movement FS-VOA chip up to 700um is available, please contact us.

## Features

- Compact
- High Reliability
- Low IL, PDL, WDL & TDL
- Intrinsic tolerance to ESD

## Performance Specifications

FS Series VOA/Shutter	Min	Typical	Max	Unit
Attenuation Resolution		Continuous		
Shutter Movement		260		$\mu\text{m}$
Response Time		20	60	ms
Optical Power Handling		400		mW
Driving Voltage <sup>[1]</sup>		3.5	4	V
Device Resistance		60 <sup>[2]</sup>	95	Ohm
Power Consumption		190	210	mW
Resonant Frequency	1000			Hz
Operating Temperature	-5		75	°C
Storage Temperature	-40		85	°C
Reliability		Telcordia 1209 and 1221		
Package Dimension		See drawing		mm

Notes:

[1]. For full dynamic range.

[2]. At voltage 3.5V.



Revised on 5/2/21  
(Click here for latest revision)

# Free Space etMEMS™ Attenuator/Shutter Chip

## Mechanical Footprint Dimensions (mm)

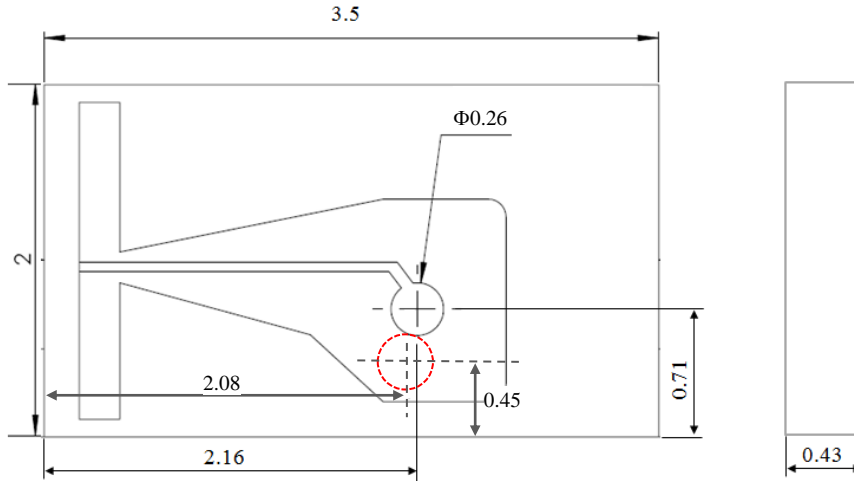

### NOTES

- The red dash-line represents the shutter position under ~3.5V.

\*Product dimensions may change without notice. This is sometimes required for non-standard specifications.

## VOA Performance

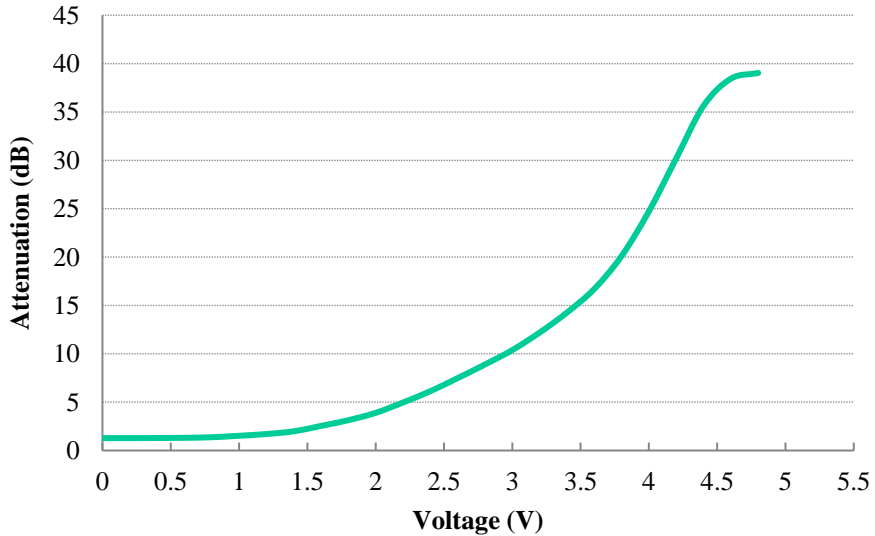

# Free Space *et*MEMS™ Attenuator/Shutter Chip

## Electronic Driving Instruction

### NOTES

- Electrode pads on front surface are for control voltage without polarity.
- Do not apply more than 5V.

## Order Instruction

P/N: FSVOA-26111010C (New standard) FSVOA-261110101-C (Old)

FSVOA -	26	1	<input type="checkbox"/>	1	0	<input type="checkbox"/>	0	C
	Shutter size	Wavelength	VOA type	Shutter surface	Package Configuration	Chip design	Electric connection	
	φ260um = 26 <sup>[1]</sup>	Broadband = 1	Standard = 1 Special = 0	Gold coated = 1	Standard = 1 No hold-chip = 0	Standard = 1 Special = 0	No PIN = 0	Bare chip = C

[1]. The different shutter size is available, please check other size FS-VOA chip data sheet.

[2]. The different orientation or customization might be available, please contact us.